

# NEC

**MODEL: NM30BS**

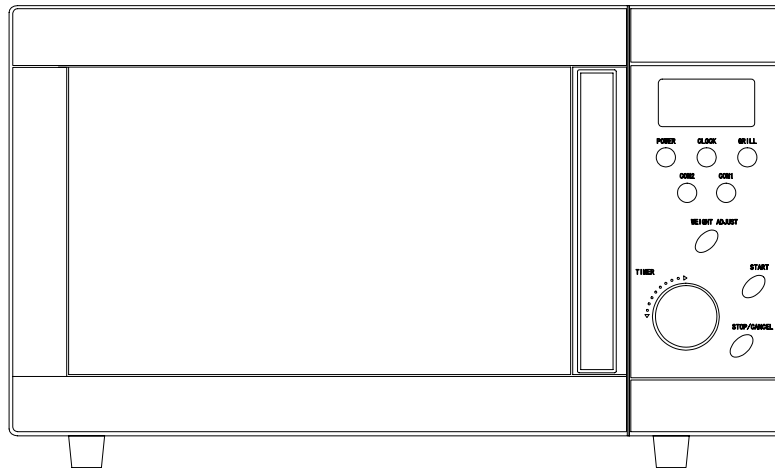

## **Microwave Oven    Owner's Manual**

Please read these instructions carefully before installing and operating the oven.

Record in the space below the SERIAL NO. found on the nameplate on your oven and retain this information for future reference.

SERIAL NO.

# PRECAUTIONS TO AVOID POSSIBLE EXPOSURE TO EXCESSIVE MICROWAVE ENERGY

1. Do not attempt to operate this oven with the door open since open door operation can result in harmful exposure to microwave energy. It is important not to defeat or tamper with the safety interlocks.
2. Do not place any object between the oven front face and the door or allow soil or cleaner residue to accumulate on sealing surfaces.
3. Do not operate the oven if it is damaged. It is particularly important that the oven door close properly and that there is no damage to the
  - a. Door (bent),
  - b. Hinges and latches (broken or loosened),
  - c. Door seals and sealing surfaces.
4. The oven should not be adjusted or repaired by anyone except properly qualified service personnel.

## CONTENTS

PRECAUTIONS TO AVOID POSSIBLE EXPOSURE TO EXCESSIVE MICROWAVE ENERGY	1
SPECIFICATIONS*	2
BEFORE YOU CALL FOR SERVICE	2
INSTALLATION	3
GROUNDING INSTRUCTIONS	3
RADIO INTERFERENCE	3
IMPORTANT SAFETY INSTRUCTIONS	4
COOKING TIPS	5
UTENSILS GUIDE	5
PART NAMES	5
CONTROL PANEL	6
MENU ACTION SCREEN	7
HOW TO SET THE OVEN CONTROLS	7
Setting clock time	7
Microwave Cooking	7
Grill	7
Combination 1	8
Combination 2	8
Auto Cook Menu	8
Auto Defrost	9
Express Cooking	9
Setting Timer	9
Child Lock	9
Special Feature	9
CLEANING AND CARE	10

## SPECIFICATIONS\*

<b>Power Consumption:</b>	<b>230V~50Hz, 1400W(Microwave)</b>
	<b>230V, 1000W(Heater)</b>
<b>Rated Microwave Power Output:</b>	<b>1000W</b>
<b>Operation Frequency:</b>	<b>2450MHz</b>
<b>Outside Dimensions:</b>	<b>305mm(H)×525mm(W)×478mm(D)</b>
<b>Oven Cavity Dimensions:</b>	<b>219mm(H)×350mm(W)×384mm(D)</b>
<b>Oven Capacity:</b>	<b>30Litres</b>
<b>Cooking Uniformity:</b>	<b>Turntable System{ Φ 314mm}</b>
<b>Net Weight:</b>	<b>Approx.19kg</b>

\*Technical specification subject to change without notice for improvement.

## BEFORE YOU CALL FOR SERVICE

If the oven fails to operate:

1. Check to ensure that the oven is plugged in securely. If it is not, remove the plug from the outlet, wait 10 seconds, and plug it in again securely.
2. Check for a blown circuit fuse or a tripped main circuit breaker. If these seem to be operating properly, test the outlet with another appliance.
3. Check to ensure that the control panel is programmed correctly and the timer is set.
4. Check to ensure that the door is securely closed engaging the door safety lock system. Otherwise, the microwave oven won't function.

IF NONE OF THE ABOVE RECTIFY THE SITUATION, THEN CONTACT A QUALIFIED TECHNICIAN. DO NOT TRY TO ADJUST OR REPAIR THE OVEN YOURSELF.

## INSTALLATION

1. Make sure that all the packing materials are removed from the inside of the door.
2. **WARNING:** Check the oven for any damage, such as misaligned or bent door, damaged door seals and sealing surface, broken or loose door hinges and latches and dents inside the cavity or on the door. If there is any damage, do not operate the oven and contact qualified service personnel.
3. This microwave oven must be placed on a flat, stable surface to hold its weight and the heaviest food likely to be cooked in the oven.
4. Do not place the oven where heat, moisture, or high humidity are generated, or near combustible materials.
5. For correct operation, the oven must have sufficient airflow. Allow 20cm of space above the oven, 10cm at back and 5cm at both sides. Do not cover or block any openings on the appliance. Do not remove feet.
6. Do not operate the oven without glass tray, roller support, and shaft in their proper positions.
7. Make sure that the power supply cord is undamaged and does not run under the oven or over any hot or sharp surface.
8. The socket must be readily accessible so that it can be easily unplugged in an emergency.
9. Do not use the oven outdoors.

## GROUNDING INSTRUCTIONS

This appliance must be grounded. This oven is equipped with a cord having a grounding wire with a grounding plug. It must be plugged into a wall receptacle that is properly installed and grounded. In the event of an electrical short circuit, grounding reduces risk of electric shock by providing an escape wire for the electric current. It is recommended that a separate circuit serving only the oven be provided. Using a high voltage is dangerous and may result in a fire or other accident causing oven damage.

**WARNING** Improper use of the grounding plug can result in a risk of electric shock.

### Note

1. If you have any questions about the grounding or electrical instructions, consult a qualified electrician or service person.
2. Neither the manufacturer nor the dealer can accept any liability for damage to the oven or personal injury resulting from failure to observe the electrical connection procedures.

The wires in this cable main are colored in accordance with the following code:

**Green and Yellow = EARTH**

**Blue = NEUTRAL**

**Brown = LIVE**

## RADIO INTERFERENCE

Operation of the microwave oven can cause interference to your radio, TV, or similar equipment.

When there is interference, it may be reduced or eliminated by taking the following measures:

1. Clean door and sealing surface of the oven.
2. Relocate the receiving antenna of radio or television.
3. Relocate the microwave oven with respect to the receiver.
4. Move the microwave oven away from the receiver.
5. Plug the microwave oven into a different outlet so that microwave oven and receiver are on different branch circuits.

## IMPORTANT SAFETY INSTRUCTIONS

When using electrical appliance basic safety precautions should be followed, including the following:

**WARNING:** To reduce the risk of burns, electric shock, fire, injury to persons or exposure to excessive microwave energy:

1. Read all instructions before using the appliance.
2. Use this appliance only for its intended use as described in this manual. Do not use corrosive chemicals or vapors in this appliance. This type of oven is specifically designed to heat and cook food and for domestic use only.
3. Do not operate the oven when empty.
4. Do not operate this appliance if it has a damaged cord or plug, if it is not working properly or if it has been damaged or dropped. If the supply cord is damaged, it must be replaced by the manufacturer or its service agent or a similarly qualified person in order to avoid a hazard
5. Children or infirm persons without adequate supervision should not operate this MWO. YOUNG Children should be supervised to ensure that they do not play the appliance.
6. Place the cookware in the cavity along with a glass half full of water .Heat on 900 W (100%) for one minute,If the cookware feels hot,you should not use it.If it is just slightly warm,you can use it for reheating but not for cooking.If the dish is room temperature,it is suitable

Paper napkins ,wax paper,paper towels,plates,cups,cartons,freezer wrap and cardboard are great convenience utensils.Always be sure containers are filled with food to absorb energy and thus avoid the possibility of over heating .

Many plastic dishes,cups,freezer containers and plastic wraps may be used in the microwave oven.Follow manufacturer's instructions when using plastics in the oven.Avoid using plastic utensils with foods that have high fat or sugar content since these foods reach high temperatures and could melt some plastics.

Do not leave oven unattended,and look at it from time to time when heating or cooking food in plastic,paper or other combustible containers.If smoker is observed,keep door closed,switch the oven until smoke stops.

Metal utensils and utensils with metallic trim should not be used in the microwave oven,unless specifically recommended for microwave use .

Containers with restricted openings,such as bottles,should not be used for microwave cooking.

Use caution when removing a lid or cover from a dish to avoid steam burns.

7. **WARNING:** Liquid or other food must not be heated in sealed containers since they are liable to explode.
8. Microwave heating of beverage can result in delayed eruptive boiling, therefore care has to be taken when handle the container.
9. Do not fry food in the oven. Hot oil can damage oven parts and utensils and even result in skin burns.
10. Eggs in their shell and whole hard-boiled eggs should not be heated in microwave ovens since they may explode even after microwave heating has ended.
11. Pierce foods with heavy skins such as potatoes, whole squashes, apples and chestnuts before cooking.
12. The contents of feeding bottles and baby jars should be stirred or shaken and the temperature should be checked before serving in order to avoid burns.
13. Cooking utensils may become hot because of heat transferred from the heated food. Potholders may be needed to handle the utensil.
14. Utensils should be checked to ensure that they are suitable for use in microwave oven.
15. **WARNING:** It is hazardous for anyone other than a trained person to carry out any service or repair operation which involves the removal of any cover which gives protection against exposure to microwave energy.

## COOKING TIPS

1. Arrange food carefully. Place thickest areas towards outside of dish.
2. Watch cooking time. Cook for the shortest amount of time indicated and add more as needed. Food severely overcooked can burn or ignite.
3. Cover foods while cooking. Covers prevent spattering and help foods to cook evenly.
4. Turn foods over once during cooking to speed cooking of such foods as chicken and hamburgers. Large items like roasts must be turned over at least once.
5. Rearrange foods such as meatballs halfway through cooking both from top to bottom and from the center of the dish to the outside.

## UTENSILS GUIDE

1. The ideal material for a microwave utensil is transparent to microwave, it allows energy to pass through the container and heat the food.
2. Microwave can not penetrate metal, so metal utensils or dishes with metallic trim should not be used.
3. Do not use recycled paper products when microwave cooking, as they may contain small metal fragments which may cause sparks and/or fires.
4. Round /oval dishes rather than square/oblong ones are recommend, as food in corners tends to overcook.
5. Narrow strips of aluminum foil may be used to prevent overcooking of exposed areas. But be careful don't use too much and keep a distance of 1 inch (2.54cm) between foil and cavity.

The list below is a general guide to help you select the correct utensils.

COOKWARE	MICROWAVE	GRILL	COMBINATION
Heat-Resistant Glass	Yes	Yes	Yes
Non Heat-Resistant Glass	No	No	No
Heat-Resistant Ceramics	Yes	Yes	Yes
Microwave-Safe Plastic Dish	Yes	No	No
Kitchen Paper	Yes	No	No
Metal Tray	No	Yes	No
Metal Rack	No	Yes	No
Aluminum Foil & Foil Containers	No	Yes	No

## PART NAMES

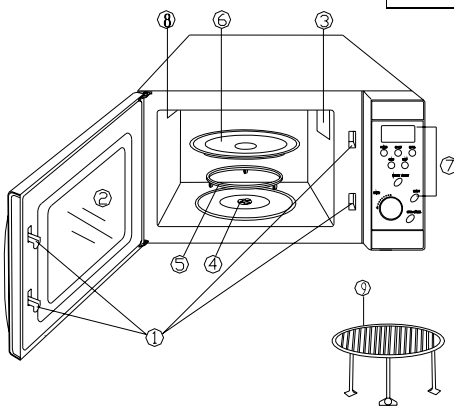

1. Door Safety Lock System
2. Oven Window
3. Oven Air Vent
4. Shaft
5. Roller ring
6. Glass Tray
7. Control Panel
8. Grill Heater
9. Metal Rack

## CONTROL PANEL

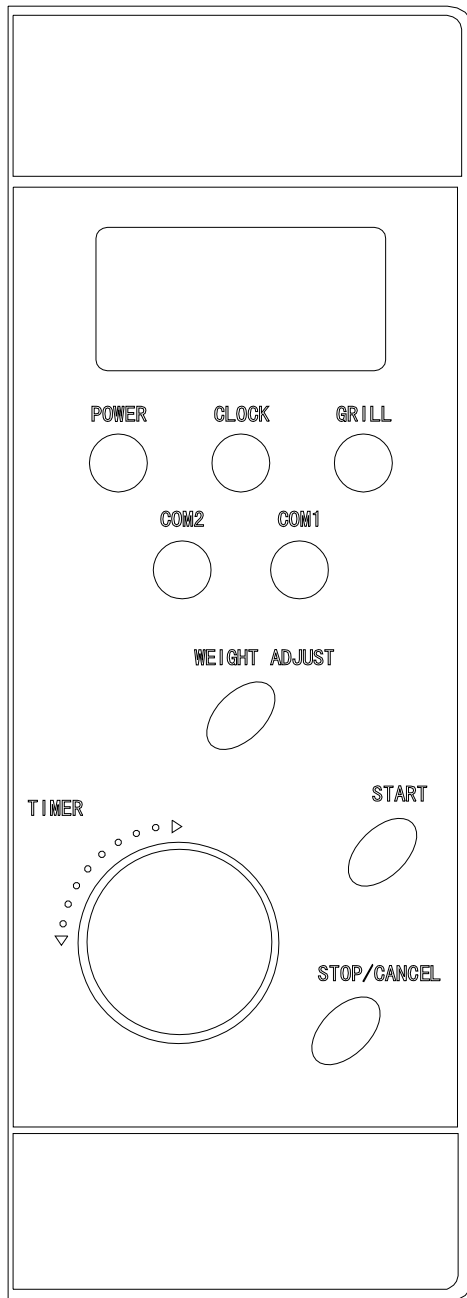

### ● MENU ACTION SCREEN

Cooking time, power, action indicators, and clock time are displayed.

### ● POWER

▶ Press this button a number of times to set microwave cooking power level.

### ● GRILL

▶ Press this button to set a grill-cooking program up to 60 minutes.

### ● COMB1/COMB2

▶ Cooking with combined microwave and grill power.

### ● TIMER

▶ Turn the dial to set the oven clock time and input cooking time.

▶ Turn the timer dial to select an auto-cooking menu including auto defrost.

### ● WEIGHT ADJ.

▶ After choosing an auto-cooking menu, use it to specify food weights or number of servings.

### ● CLOCK

▶ Press this button to start setting the oven clock and ending by touching it again.

### ● START

▶ Press to start a cooking program.

▶ Simply Press it a number of times to set cooking time and cook immediately at full power level.

### ● STOP/CANCEL

▶ Press to cancel setting or reset the oven before setting a cooking program.

▶ Press once to temporarily stop cooking, or twice to cancel cooking altogether.

▶ It is also used for setting child lock.

NOTE: Layout and button/operator names may undergo slight changes which have no bearing on operation of the control panel.

## MENU ACTION SCREEN

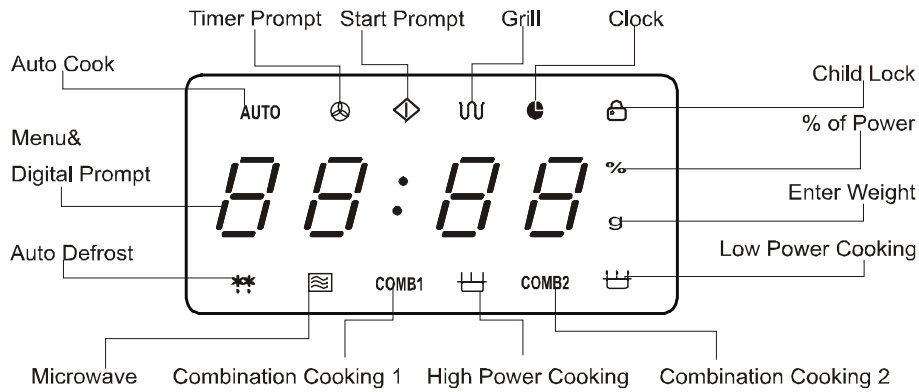

## HOW TO SET THE OVEN CONTROLS

Each time a button is touched, a beep will sound to acknowledge the touch.

### SETTING CLOCK TIME

When the oven is first plugged in, the display shows "1:01", this is a 12-hour clock. To check the time while the oven is operating, press the CLOCK button, then the time will be displayed for 5 seconds in the display.

FOR EXAMPLE: Suppose you want to set the oven clock time to 8:30 (A.M. or P.M.).

1. Press STOP/CANCEL button.
2. Press CLOCK button.
3. Turn TIMER to set 8 o'clock.
4. Press CLOCK button.
5. Turn TIMER to set 30 min.
6. Press CLOCK to confirm the setting.

### MICROWAVE COOKING

For microwave cooking, just press the POWER button a number of times to select a cooking power level, and then use the TIMER dial to set a desired cooking time. The longest cooking time is 60 minutes.

Select power level by pressing the POWER button.

PRESS POWER BUTTON	DISPLAY	COOKING POWER
once	100	100%

twice	80	80%
3 times	60	60%
4 times	40	40%
5 times	20	20%
6 times (setting timer)	0	0

For example, suppose you want to cook for 1 minute at 60% of microwave power.

1. Press STOP/CANCEL button to reset the oven.
2. Press POWER button 3 times.
3. Turn TIMER to 1:00.
4. Press START button.

### GRILL

The longest cooking time is 60 minutes. The grill cooking is particularly useful for thin slices of meat, steaks, chops, kebabs, sausages or piece of chicken. It is also suitable for hot sandwiches and au gratin dishes.

For example, suppose you want to grill for 12 minutes.

1. Press STOP/CANCEL button.
2. Press GRILL button.
3. Turn the TIMER to 12:00.
4. Press START button.



### COMBINATION 1

The longest cooking time is 60 minutes.

30% time for microwave cooking, 70% for grill cooking. Use for fish, potatoes or au gratin.

FOR EXAMPLE: Suppose you want to set combination 1 cooking for 25 minutes.

1. Press STOP/CANCEL button.
2. Press COM1 button.
3. Turn TIMER to 25:00.
4. Press START button.

### COMBINATION 2

The longest cooking time is 60 minutes.

55% time for microwave cooking, 45% for grill cooking. Use for puddings omelettes, baked potatoes and poultry.

FOR EXAMPLE: Suppose you want to set combination 2 cooking for 12 minutes.

1. Press STOP/CANCEL button.
2. Press COM 2 button.
3. Turn TIMER to 12:00.
4. Press START button.

### AUTO COOK MENU

For the following foods or cooking operation, you do not need to input cooking power and time. Try to focus on telling the oven what you want to cook and how much the food weighs. You can do so by turning the TIMER dial to select a food/operation category, then press the WEIGHT ADJ. button to indicate the number of servings or approximate weights of food you are about to cook. The oven starts to work after you touching the START button.

You may need to turn food over at the middle of cooking time to obtain uniform cooking.

For example, to cook 400g of fish..

1. Press STOP/CANCEL button.
2. Turn TIMER dial to fish cooking, which is the item 6 on the auto-menu.
3. Press WEIGHT ADJ. button 8 times to indicate weights 400g.
4. Press START button.

AUTO MENU		Press WEIGHT ADJ., to indicate weights or number of servings								
		1	2	3	4	5	6	7	8	9
1.	Coffee/Soup	1cup	1soup	2 soup						
2.	Rice	80g	100g	120g						
3.	Spaghetti	100g	200g	300g						
4.	Potatoes	150g	300g	450g	600g					
5.	Reheating	70g	140g	210g	280g	320g	350g	380g	420g	450g
6.	Fish	50g	100g	150g	200g	250g	300g	350g	400g	450g
7.	Chicken	800g	1000g	1200g	1300g	1400g	1500g	1700g	1800g	2000g
8.	Beef/Mutton	300g	500g	800g	1000g	1200g	1300g	1800g		
9.	Skewered Meat	80g	100g	150g	200g	300g	400g	500g	600g	700g
10.	Auto Defrost									

However, please remember that the result of auto cooking depends on factors such as voltage. the shape and size of food, your personal preference as to the doneness of certain foods and even how well you happen to place the food in the oven. If you find the result at any rate not quite satisfactory, please adjust the cooking time a little bit accordingly.

## **AUTO DEFROST**

---

The oven can be used to defrost meat, poultry, and seafood. The defrosting time and power level are automatically set once the food category and the weight are programmed. The frozen food weight ranges from 100g to 4000g.

FOR EXAMPLE: Suppose you want to defrost 600g of shrimp.

1. Press STOP/CANCEL button.
2. Turn TIMER to defrost setting by turning the dial until it have passed the 9th auto cook menu, and then turn the dial again to indicate weight 600g.
3. Press START button.

## **EXPRESS COOKING**

---

The oven will operate at HIGH power (100% power output) for EXPRESS cooking program.

With each press of the START button you can program the oven for the following settings:

TIME	PRES START BUTTON
0:30	once
1:00	twice
1:30	thrice
...	...
12:00	15 times

For example, to set the oven to cook for 2 minutes using this feature:.

1. Press STOP/CANCEL button.
2. Press START button 4 times, the oven starts working immediately at full power.

## **SETTING TIMER**

---

The minute timer will enable you to set a countdown time. The oven light, turntable,

and cooling fan are in operation, but there is no microwave radiation. You may use this feature in case you want to time cooking operation.

For example, suppose you want to set timer for 3 minutes.

1. Press STOP/CANCEL button.
2. Press POWER button 6 times
3. Turn TIMER to 3:00.
4. Press START button.

## **CHILD LOCK**

---

Use to prevent unsupervised operation of the oven by little children. The CHILD LOCK indicator will show up on display screen, and the oven can not be operated while the CHILD LOCK is set.

To set the CHILD LOCK: Press and hold the STOP/CANCEL button for 3 seconds, a beep sounds and LOCK indicator lights.

To cancel the CHILD LOCK: Press and hold the STOP/CANCEL button for 3 seconds until lock indicator on display goes off.

## **SPECIAL FEATURE**

---

### **AUTO REMINDER**

After a cooking or defrosting program has completed, the oven will automatically continue to sound three beeps every two minutes until the oven door is opened or the CANCEL button is pressed.

## CLEANING AND CARE

1. Turn off the oven and remove the power plug from the wall socket before cleaning.
2. Keep the inside of the oven clean. When food splatters or spilled liquids adhere to oven walls, wipe with a damp cloth. Mild detergent may be used if the oven gets very dirty. Avoid the use of spray and other harsh cleaners as they may stain, streak or dull the door surface.
3. The outside surfaces should be cleaned with a damp cloth. To prevent damage to the operating parts inside the oven, water should not be allowed to seep into the ventilation openings.
4. Wipe the door and window on both sides, the door seals and adjacent parts frequently with a damp cloth to remove any spills or splatters. Do not use abrasive cleaner.
5. Do not allow the control panel to become wet. Clean with a soft, damp cloth. When cleaning the control panel, leave oven door open to prevent oven from accidentally turning on.
6. If steam accumulates inside or around the outside of the oven door, wipe with a soft cloth. This may occur when the microwave oven is operated under high humidity condition. And it is normal.
7. It is occasionally necessary to remove the glass tray for cleaning. Wash the tray in warm sudsy water or in a dishwasher.
8. The roller ring and oven floor should be cleaned regularly to avoid excessive noise. Simply wipe the bottom surface of the oven with mild detergent. The roller ring may be washed in mild sudsy water or dishwasher. When removing the roller ring from cavity floor for cleaning, be sure to replace in the proper position.
9. Remove odors from your oven by combining a cup of water with the juice and skin of one lemon in a deep microwaveable bowl, microwave for 5 minutes. Wipe thoroughly and dry with a soft cloth.
10. When it becomes necessary to replace the oven light, please consult a NEC Services Center or NEC Pro Care Center to have it replaced.